

Soldering/Taping Specifications

Immersion Method

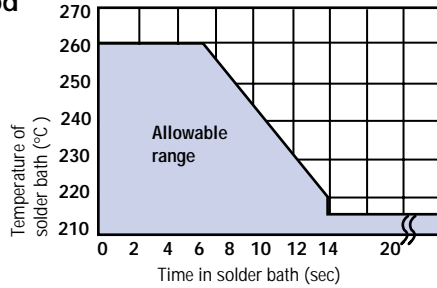

Reflow Method

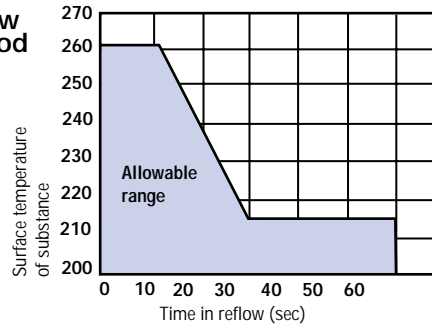

Tape and Reel Specifications

Dimensions

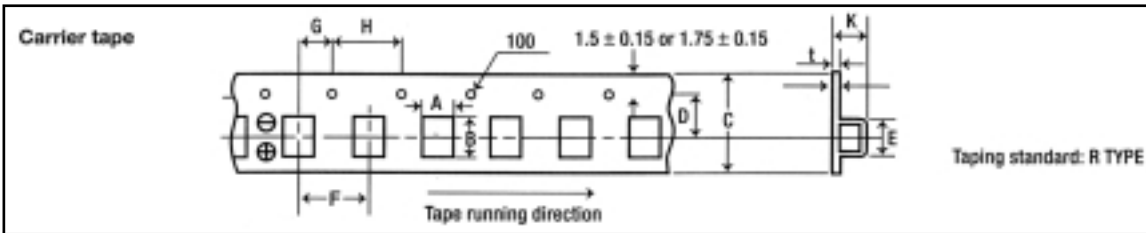

Dimension	Case Code A	Case Code B	Case Code C	Case Code D	Case Code E
A	1.9±0.1	3.1±0.1	3.7±0.1	4.8±0.1	4.8±0.1
B	3.5±0.1	3.8±0.1	6.4±0.1	7.7±0.1	7.7±0.1
C	8.0±0.3	8.0±0.3	12.0±0.3	12.0±0.3	12.0±0.3
D	3.5±0.05	3.5±0.05	5.65±0.05	5.65±0.05	5.7±0.05
E	4.7 max	5.0 max	7.3 max	8.4 max	8.4 max
F	4.0±0.1	4.0±0.1	8.0±0.1	8.0±0.1	8.0±0.1
G	2.0±0.05				
H	4.0±0.1				
T	1.5±0.1, -0				
I	0.2	0.3	0.3	0.3	0.3
K	2.0 max	2.1±0.2	3.0±0.2	3.6±0.2	4.7±0.2
Carrier Tape	Emboss Plastic				
Cover tape	Polyester				

(mm)

Reel Specifications

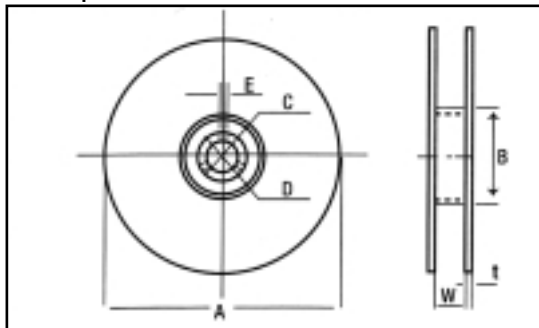

A	B	C	D	E	W	F
178±2.0	50 min.	13.0±0.5	21.0±0.8	2.0±0.5	10.0±1.5(C:8.0) 14.0±1.5(C:12.0)	2.0±0.5

(mm)

Quantities Per Packaged Reel

Case Code	Reel
A	2,000
B	2,000
C	500
D	500
E	400